

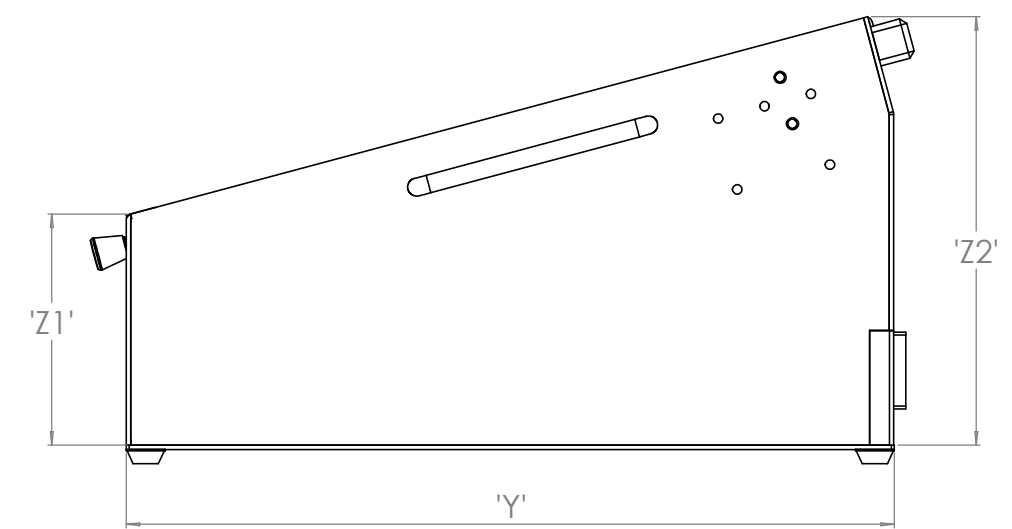

REV	DESCRIPTION	WHO	DATE
A	RELEASED PER ORIGINAL SPECIFICATION		

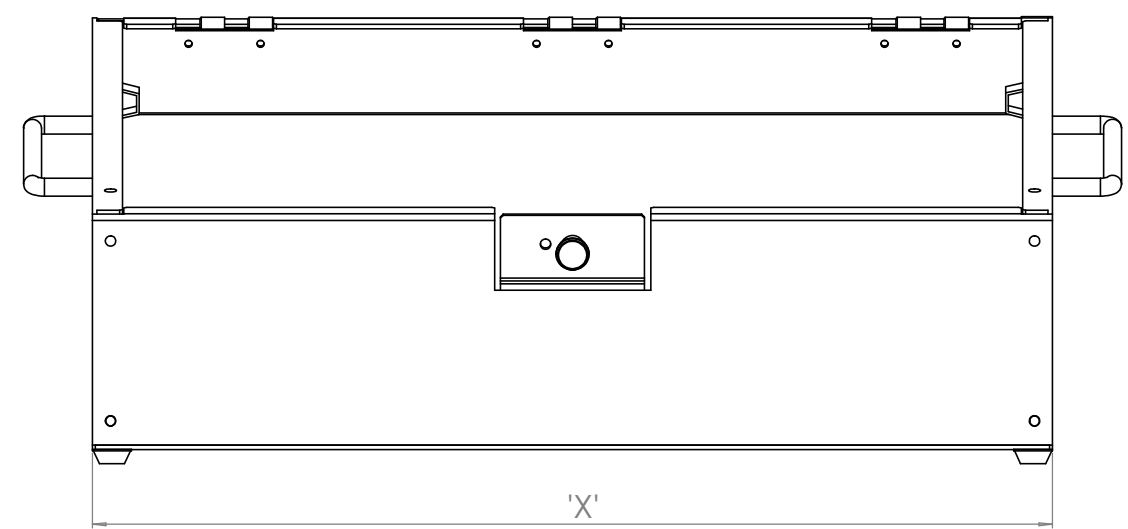
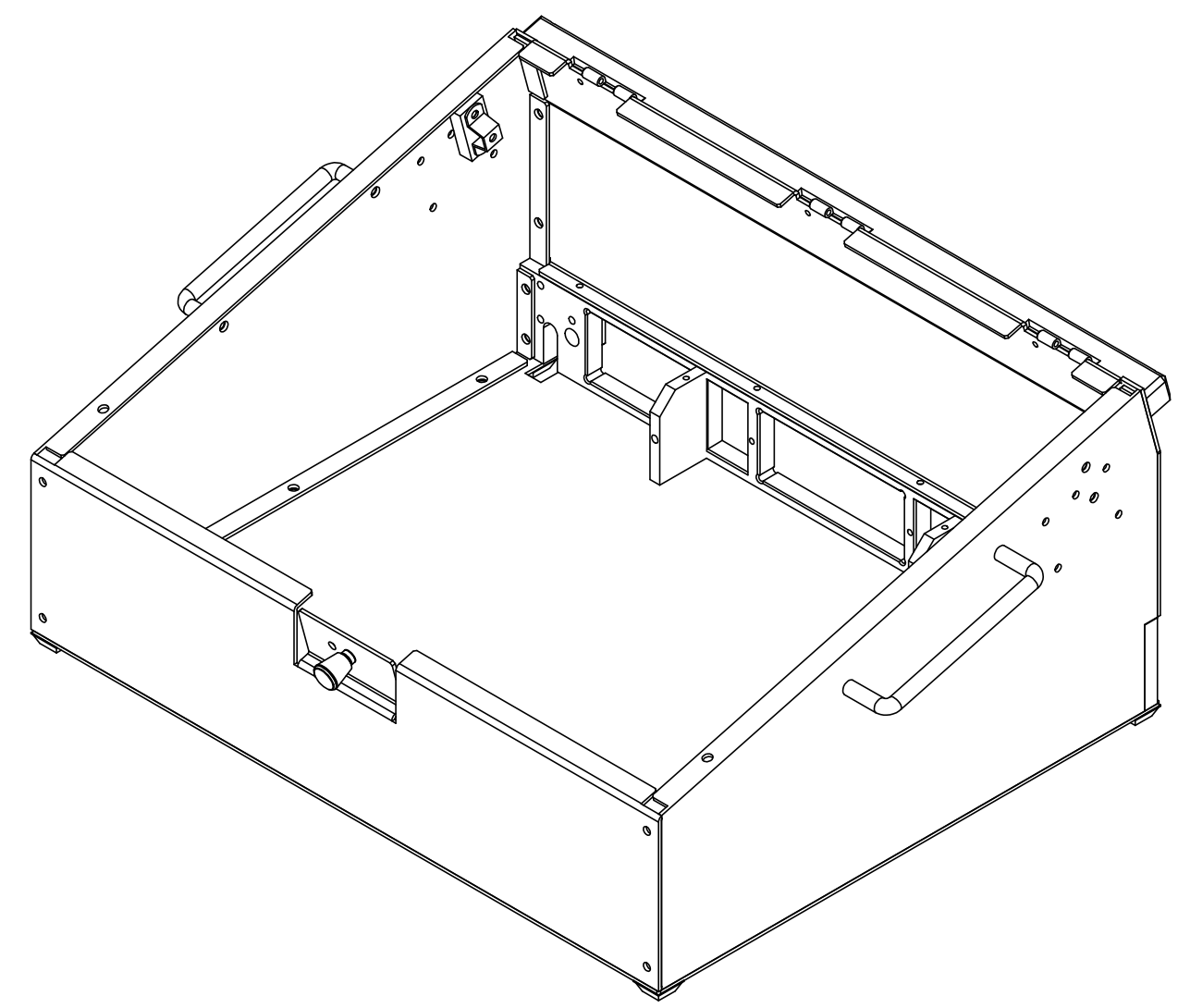
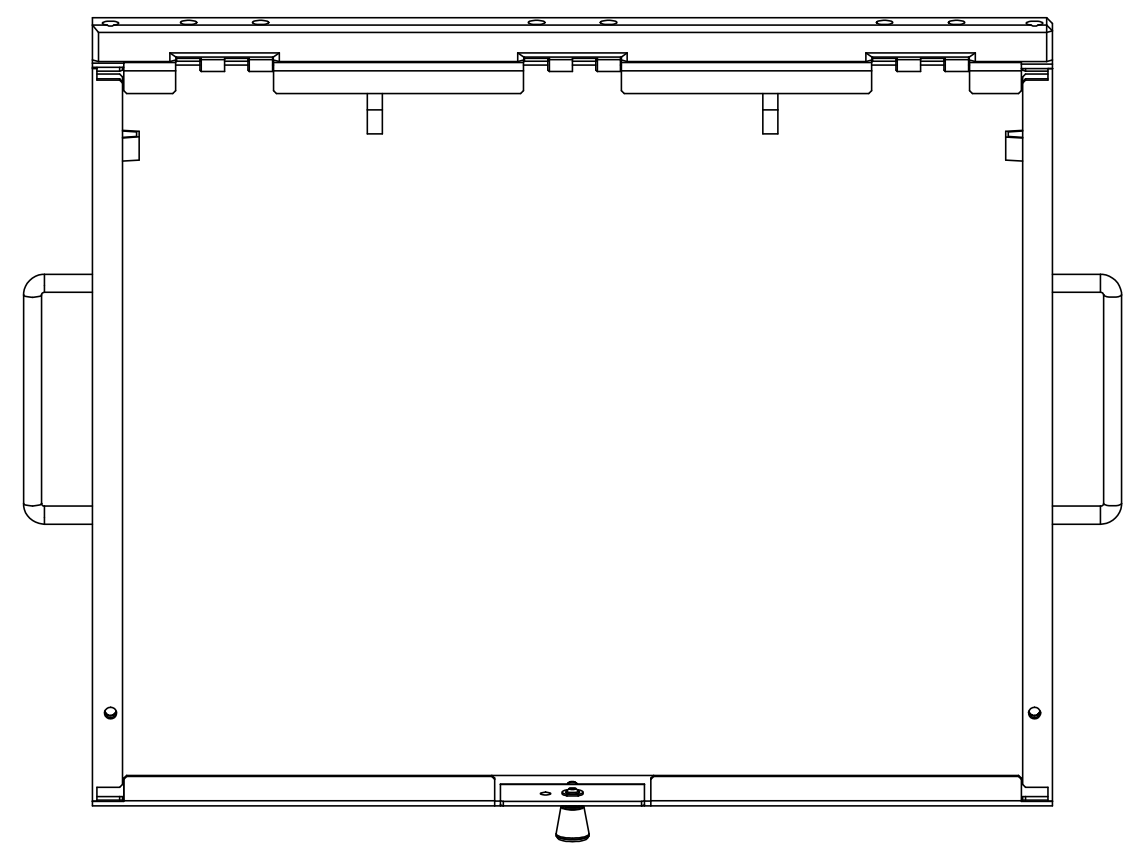

SERIES 3000 SLOPE PAN DIMENSIONS				
SERIES 3000 SLOPED PAN DIMENSIONS				
ASM NUMBER	X	Y	Z1	Z2
ASM-3006-SLP-PAN	20.00" [508mm]	16.00" [406.4mm]	4.80" [121.9mm]	8.95" [226.1mm]
ASM-3008-SLP-PAN	24.00" [609.6mm]	20.00" [508mm]	4.80" [121.9mm]	9.95" [254.7mm]

MATERIAL:
TREATMENT/FINISH:
NEXT ASSEMBLY:

INTERPRET GEOMETRIC & ELECTRICAL SYMBOLS PER ANSI STANDARDS	DRAWN BY	14 HIGH STREET PLAINVILLE, MA. 02762 (508) 384-8303
UNLESS OTHERWISE SPECIFIED USE THE FOLLOWING	DATE	
DEBURR & BREAK ALL SHARP EDGES APPROXIMATELY 0.01" ± 45°	CHECKED BY	
	DATE	
TOLERANCE ON DIMENSIONS	125 / MAXIMUM MACHINE FINISH	LAST SAVED BY
2 PLACE	±.01 INCH ±.25mm	DATE
3 PLACE	±.005 ±.127mm	APPROVED BY
4 PLACE	±.0005 ±.0127mm	RELEASE DATE
ANGLES	±30° ±30°	

DESCRIPTION
SERIES 3000 SLOPED PAN
ASSEMBLY DIMENSIONS

SIZE: D PART/ASSEMBLY NUMBER: SHEET 1 of 1

DRAWING VIEWS PROJECTED USING 3RD ANGLE

SEMCO PROPRIETARY
THIS DOCUMENT IS THE PROPERTY OF SEMCO MACHINE CORPORATION. IT IS TO BE RETURNED UPON REQUEST. REPRODUCTION BY ANY MEANS, DISCLOSURE, OR USE OF ITS CONTENTS FOR WHICH IT IS LOANED, WITHOUT WRITTEN CONSENT OF SEMCO MACHINE CORPORATION IS STRICTLY PROHIBITED.