

| REV | DESCRIPTION | WHO | DATE |
|-----|-------------------------------------|-----|------|
| A | RELEASED PER ORIGINAL SPECIFICATION | | |

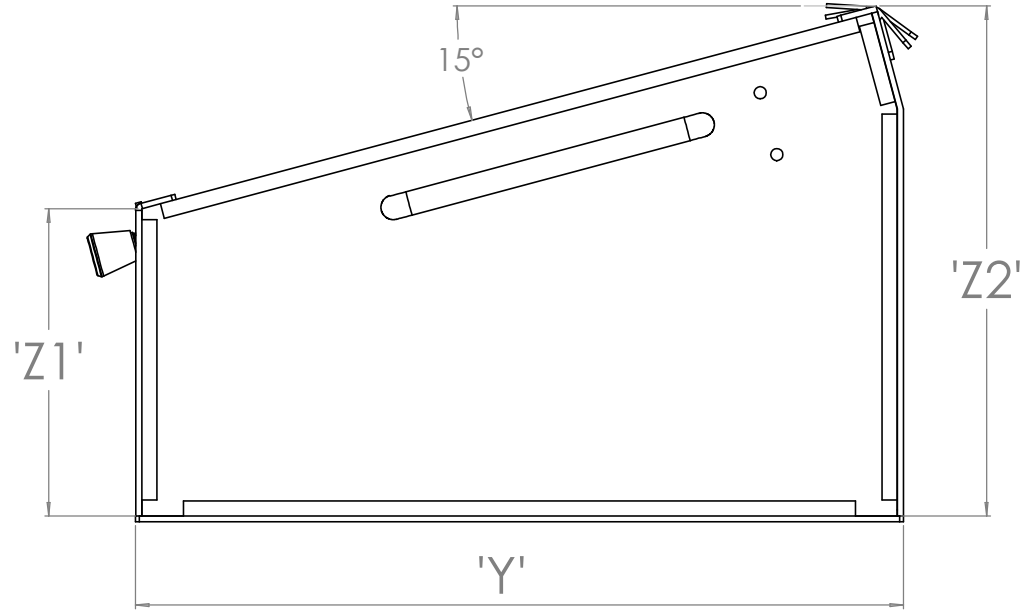
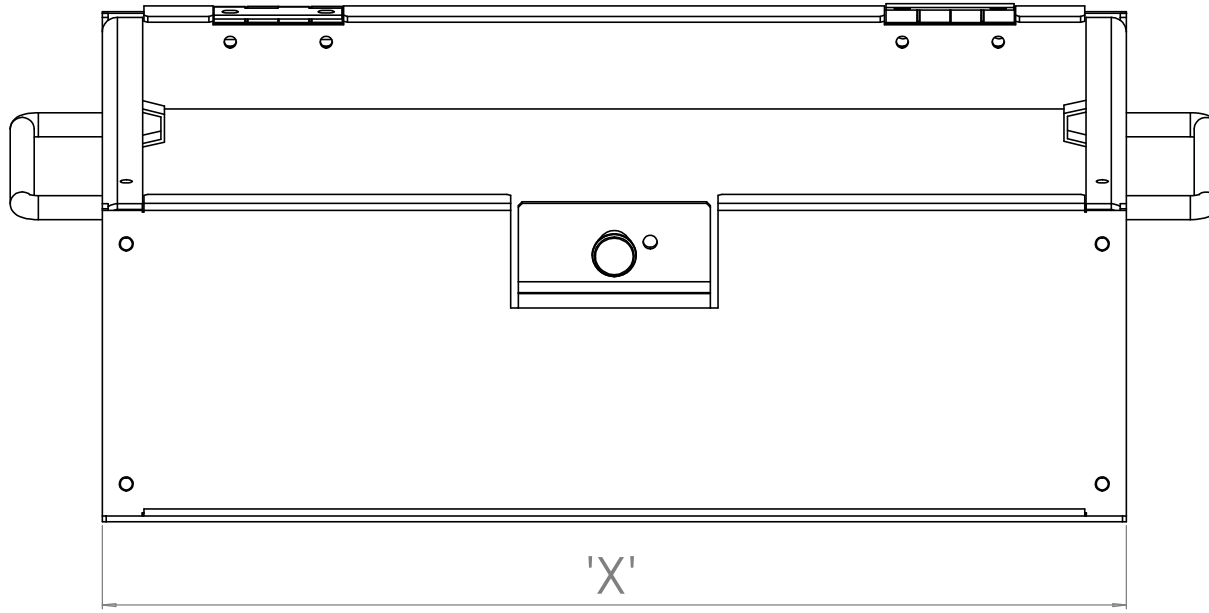
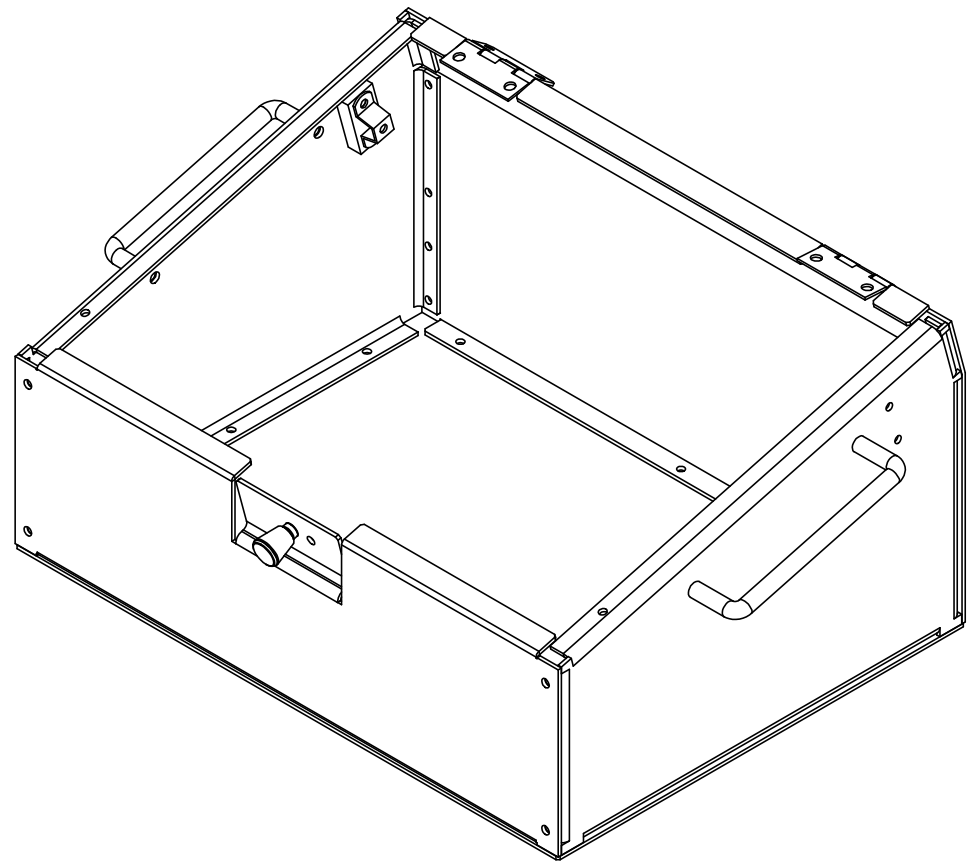
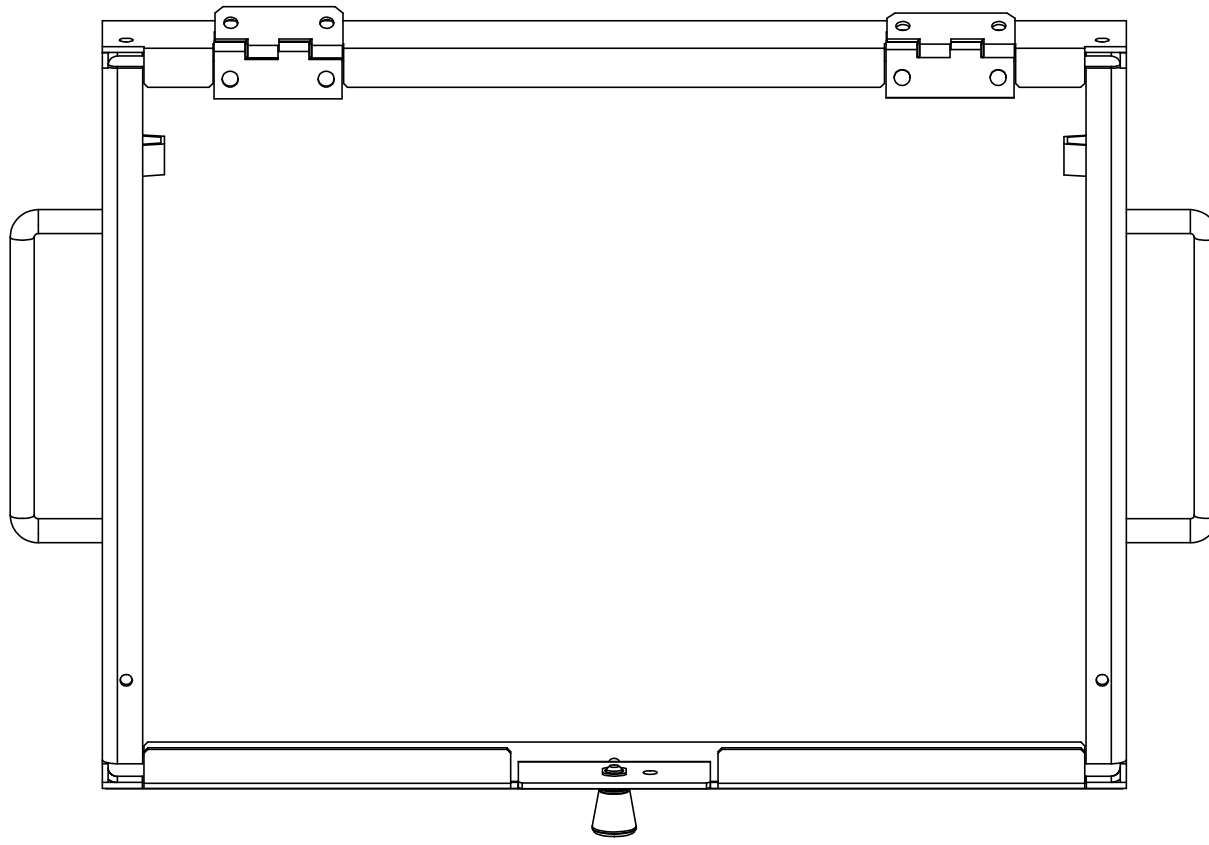

| SERIES 1000 SLOPE PAN DIMENSIONS | | | | |
|----------------------------------|------------------|------------------|-----------------|-----------------|
| ASM NUMBER | X | Y | Z1 | Z2 |
| ASM-1002-SLP-PAN | 12.00" [304.8mm] | 8.00" [203.2mm] | 2.75" [69.8mm] | 4.80" [121.9mm] |
| ASM-1003-SLP-PAN | 12.00" [304.8mm] | 16.00" [406.4mm] | 4.80" [121.9mm] | 8.90" [226.1mm] |
| ASM-1004-SLP-PAN | 16.00" [406.4mm] | 12.00" [304.8mm] | 4.80" [121.9mm] | 7.90" [200.6mm] |
| ASM-1006-SLP-PAN | 20.00" [508mm] | 16.00" [406.4mm] | 4.80" [121.9mm] | 8.90" [226.1mm] |
| ASM-1008-SLP-PAN | 24.00" [609.6mm] | 20.00" [508mm] | 4.80" [121.9mm] | 9.95" [254.7mm] |
| ASM-1010-SLP-PAN | 30.00" [762mm] | 20.00" [508mm] | 4.80" [121.9mm] | 9.95" [254.7mm] |

MATERIAL:

TREATMENT/FINISH:

NEXT ASSEMBLY:

| | | |
|---|----------------------------|---|
| INTERPRET GEOMETRIC & ELECTRICAL SYMBOLS PER ANSI STANDARDS | DRAWN BY | 14 HIGH STREET PLAINVILLE, MA. 02762 (508) 384-8303 |
| UNLESS OTHERWISE SPECIFIED USE THE FOLLOWING | DATE | |
| DEBURR & BREAK ALL SHARP EDGES APPROXIMATELY 0.01 ± 45° | CHECKED BY |  DESCRIPTION SERIES 1000 SLOPE PAN DIMENSIONS |
| | DATE | |
| TOLERANCE ON DIMENSIONS | 125 MAXIMUM MACHINE FINISH | LAST SAVED BY |
| 2 PLACE | INCH ±.01 | DATE |
| 3 PLACE | METRIC ±.005 | |
| 4 PLACE | ±.0005 | APPROVED BY |
| ANGLES | ±30' | RELEASE DATE |

SCALE 1:2 SHEET 1 of 1

DRAWING VIEWS PROJECTED USING 3RD ANGLE

SEMCO PROPRIETARY

THIS DOCUMENT IS THE PROPERTY OF SEMCO MACHINE CORPORATION. IT IS TO BE RETURNED UPON REQUEST. REPRODUCTION BY ANY MEANS, DISCLOSURE, OR USE OF ITS CONTENTS FOR WHICH IT IS LOANED, WITHOUT WRITTEN CONSENT OF SEMCO MACHINE CORPORATION IS STRICTLY PROHIBITED.